

WHAT IS MECO'S OFS TYPE 2 SEAL?

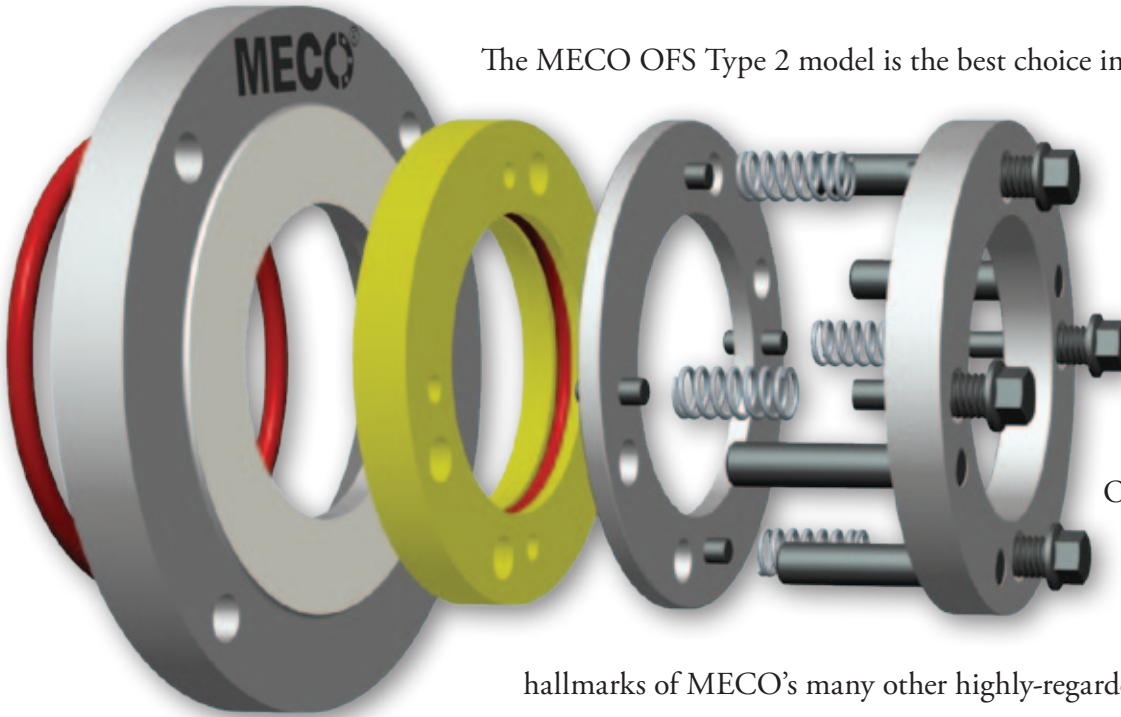

The MECO OFS Type 2 model is the best choice in many sealing applications for low to moderate speed equipment. The OFS Type 2 uses full contact, soft face mechanical shaft sealing technology, sized for OEM and custom in-house process equipment. The OFS Type 2 model provides the superior performance, durability and quality of workmanship that are hallmarks of MECO's many other highly-regarded seals. MECO's first rate customer service is provided for each OFS Type 2 seal sold.

WHEN ARE OFS TYPE 2 SEALS THE BEST OPTION?

The OFS Type 2 seal model is ideal for blenders, mixers, cookers, conveyors and similar rotating equipment used in the food, pharmaceutical, chemical, plastics, metals, and other bulk process industries. The OFS Type 2 seal model is used on horizontal, inclined, and top entering shafts for split and unsplit installations. They are frequently used in dry powder blending applications including sugar drink mixes, spices, flavorings, nutrients, plastic and metal powders, and chemicals. It is also used in wet mixing for products like soups, sauces & pet foods.

The OFS Type 2 seal model does not require compressed air. Thus, letting users steer clear of the cost and hassles associated with compressed air use. The seal is extremely effective in vacuum service.

The OFS Type 2 seal model allows for easy speedy cleaning. The seal may be washed in 10 minutes time while assembled on the blender or freely disassembled along the shaft for cleaning and inspection.

The MECO Outside Face Seal is a rugged, reliable solution for containing hard-to-seal products, while offering exceptional cleanability and ease of maintenance.

HOW DOES THE OFS TYPE 2 SEAL MODEL WORK?

The OFS Type 2 seal model replaces stuffing boxes, lip seal housings and other types of seals. It is made with a heavy, hardened stainless steel stationary seal face or stator that bolts directly to the machine. A low friction rotating seal face is at a right angle to the shaft and in full contact with the stator. Sealing along the shaft is accomplished with an O-ring contained in the rotor that turns with the shaft and rotor. A drive collar, with large drive pins and self contained springs, locks to the shaft at a predetermined distance from the rotor. Factory calibration is set by fully tightening the spring actuators, providing the seal face closing force.

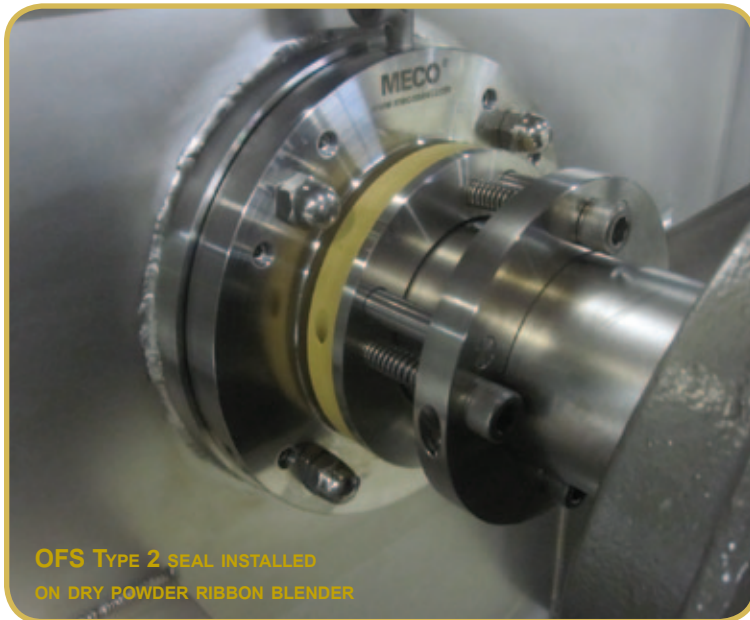

HOW IS THE OFS TYPE 2 MAINTAINED?

The OFS Type 2 seal model is easily maintained. The seal is easily disassembled for cleaning and resetting the spring load. By loosening the spring actuators, drive collar and rotor split-line, the parts may be pulled back for inspection and cleaning. Reassembly sets the seal face closing force to original values. An optional seal flush port enters just ahead of the stationary seal face. The flush enters through the stator, flushing the recessed area between the blender interior wall and dynamic sealing interface. The seal flush then enters the blender and exits out the blender's discharge valve. The external parts of the seal are easily hosed off following Good Manufacturing Practice (GMP).

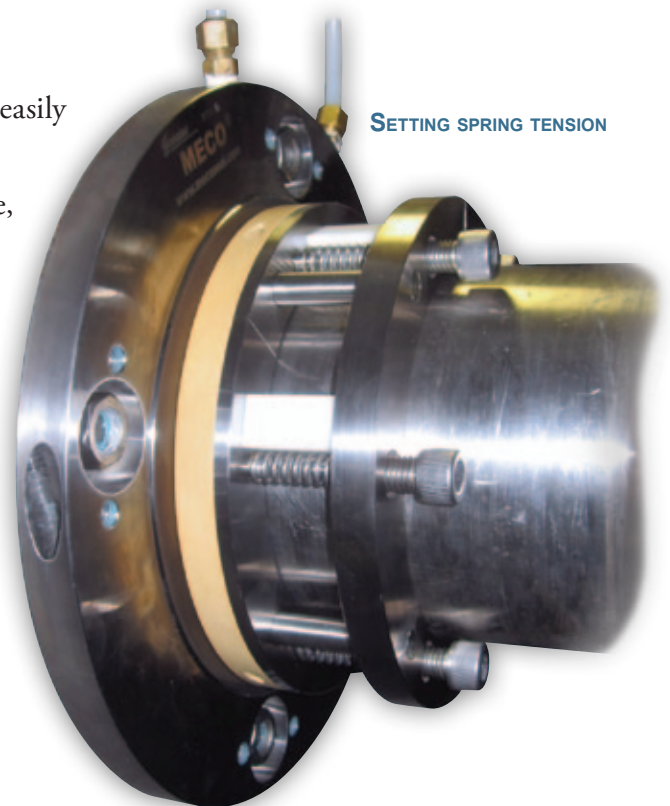

WWW.MECOSEAL.COM

MECO[®] Driven.
SEALS

OFS MODEL TYPICAL DIMENSIONS

WHAT SIZES ARE AVAILABLE?

OFS Type 2 seals are not inventory or “off the shelf” seals. They are custom designed and built to order. Dimensions will vary according to each application, but typical dimensions are shown in the illustration at right. They are readily designed to fit most mounting arrangements specified by blender and cooker OEMs and are designer-friendly, to interface with customized, in-house process equipment requirements. Seals can be built either to S.A.E or metric dimensions.

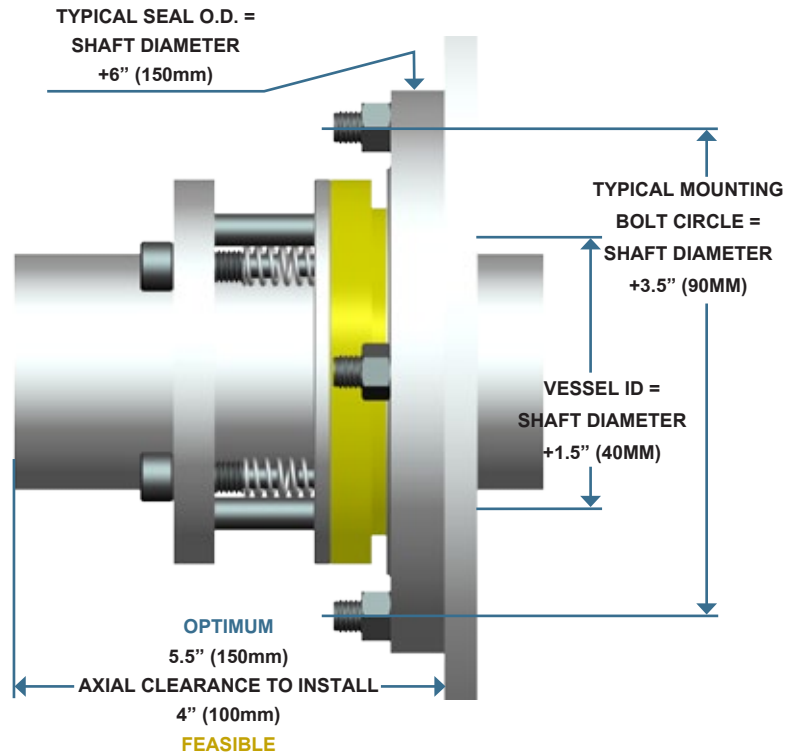

WHAT CONSTRUCTION IS AVAILABLE?

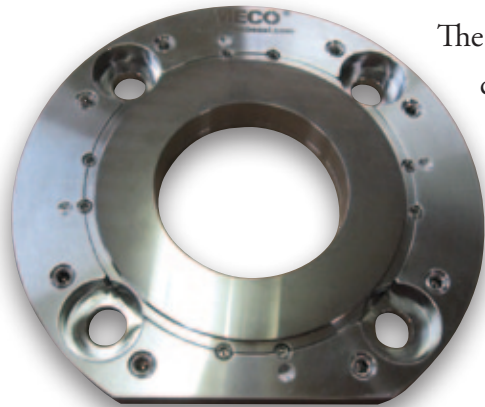

OFS TYPE 2 HOUSING WITH REMOVABLE STATOR

The OFS Type 2 seal’s rugged components are designed for long life. Standard configuration uses a hardened stainless steel stationary seal face. The standard rotor is MECO 3000, a high performance, bearing grade, polymer filled PTFE with FDA approval. No abrasive filler material is added to the MECO 3000. The standard elastomer for the O-ring is FDA Viton®. For large shaft diameters or highly-abrasive process materials, a replaceable hardened stator insert, the polished central ring at left, can be offered. MECO seals can be fabricated from a wide variety of suitable materials.

Viton® is a registered trademark of E.I. DuPont de Nemours & Company

Mechanical Capabilities	
Temperature	-60° to 425° f (-50° to 218° C)
Pressure	Vacuum to 10 psig (70 kPa)
Shaft Speed	Up to 290 RPM
T.I.R. Runout	1/4" (6mm) standard; greater runout can be accommodated
Repeated Axial Shaft Motion	1/64" (0.4mm)
Thermal Shaft Growth	1/8" (3mm) typical; actual limits are set by physical space and application parameters
Results may vary with operating conditions - please call for discussion.	

MECO OFS TYPE 2

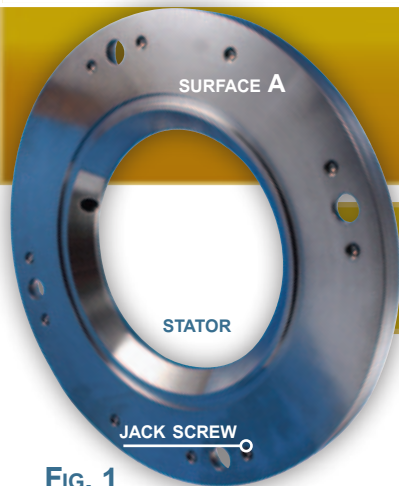

FIG. 1

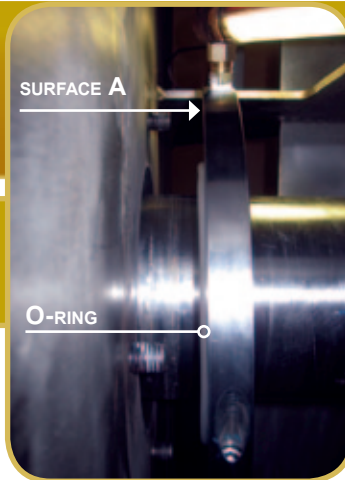

FIG. 2

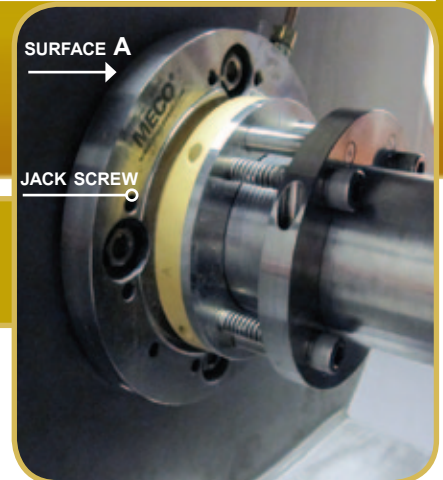

FIG. 3

HOW DOES THE OFS TYPE 2 MODEL SEAL TO THE EQUIPMENT?

Meco offers O-rings, gaskets & bedding compounds as static sealing options between the OFS TYPE 2 seal stator (Surface A above) and the blender wall. An approach following USDA guidelines with an adjustable mounting feature is shown above in Figures 1-3.

FIGURE 1 - Often the OFS Type 2 seal has an O-ring groove and a large chamfer machined into the back of the stator on Surface A. The groove detail and chamfer minimize product retention time in dead spaces while maximizing blending performance and facilitating inspection.

FIGURE 2 - An O-ring fits in the groove and forms a static seal against the end wall following USDA fabrication guidelines.

FIGURE 3 - Jacking screws assist in mounting the OFS Type 2 seal's stator assembly perpendicular to the shaft and maintaining stator surface flatness.



MECO's design staff or your local distributor can help tailor the OFS Type 2 to your individual needs.

Below are a few examples of other MECO seal models.

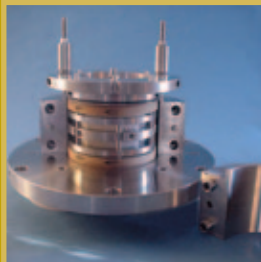

EP Model

- Reactor Vessels
- Dryers
- Extruders



AH Model

- Blenders
- Screw Conveyors
- Tight Spaces



MP Model

- Air locks
- Rotary Feeders



HB Model

- Standard Seals for C.E.M.A. and Metric Screw Conveyors



EA Model

- Abrasive Slurries
- Adjustable on-the-Fly
- Large Diameters

Distributed by: